



PERFORMANCE IMPROVEMENT IN REGENERATIVE AIR PREHEATERS

VOLUME 1, ISSUE 2

AUTHOR :- A. R. KULKARNI, DIRECTOR

PUBLISHED DATE :- 04/11/2009

In India, majority of boilers in power industry, are provided with rotary regenerative type air pre heaters. These being LUNGS of the boiler, need to be kept in healthy condition to have proper and efficient ventilation.

Most common problems associated with these air pre heaters are

1. Seal leakages
2. Erosion of heating elements on HOT end side.
3. Choking up of heating elements at inboard side of HOT end & COLD end sides

All of these result in poor thermal performance of APH's, loss in boiler efficiency, and reduction in generation due to lost margins of I.D. fans.

AIR HEATER WORKING PRINCIPLE

Air pre-heater transfer heat from flue gas to air by means of a rotary matrix in which heat is absorbed by the heating elements passing through the hot gas stream and transferred to the combustion air stream.

As leakages increase, more & more air enters the flue gas path. As a result, equipment down stream of air preheater have to handle increased mass of the flue gas & hence fans consume more power. Increased power consumption affects net heat rate. Seal are provided to avoid radial leakages, periphery leakages & also the axial leakages. In addition to this, some air trapped between two diaphragms also finds way to gas side when

rotor enters the flue gas side. Figure alongside shows a principle sketch of the pre-heater.

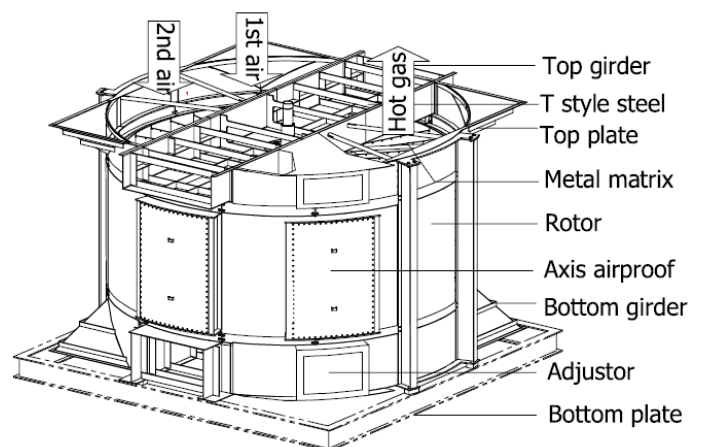



PERFORMANCE IMPROVEMENT IN REGENERATIVE AIR PREHEATERS

SEAL LEAKAGES

Air leaks across radial and by-pass seals to flue gas side. Leakages are measured by comparing oxygen content of the flue gas entering and leaving airpreheater.

$$\text{Leakages} = \frac{100 * (O_{2out} - O_{2in})}{(20.9 - O_{2out})}$$



This calculated leakage includes leakages through radial seals on hot and cold end sides together and is measured as percent of air flow.. Flue gas leakage across bypass seals is not accounted for. O₂ content does not vary as gases bypass air heater totally and leave APH without transferring heat to heating elements and in turn air stream, which result in increased flue gas temperature at outlet and increased loading on Electro static precipitators. Similarly air bypassing APH is not getting heated reducing air outlet temperature. Heat loss occurred reduces boiler efficiency. Leakages can be as high as 15 to 20 percent. And are difficult to measure.

Utmost care needs to be taken while setting bypass

seals. Flexible seals are developed to reduce leakages through radial seals. Modified 'T' bars along with flexible seals are also developed to reduce leakages across bypass seals.

High flue gas velocity on outboard side causes heavy erosion of heating elements at outer baskets. Comparatively less erosion is observed on inboard side baskets. Non-uniform distribution of flue gas entering APH from economizer is the main reason. If coarse fly ash from economizer hoppers is not evacuated regularly, heap of ash forms in these hoppers. The heaps not only affect flue gas distribution but also spill over to APH causing erosion. Non uniform distribution of gas also causes erosion of 'T' bars, rotor angle, bypass seals and rear side duct plates from economizer to APH along with expansion joints.

Erosion pattern on out board side of APH

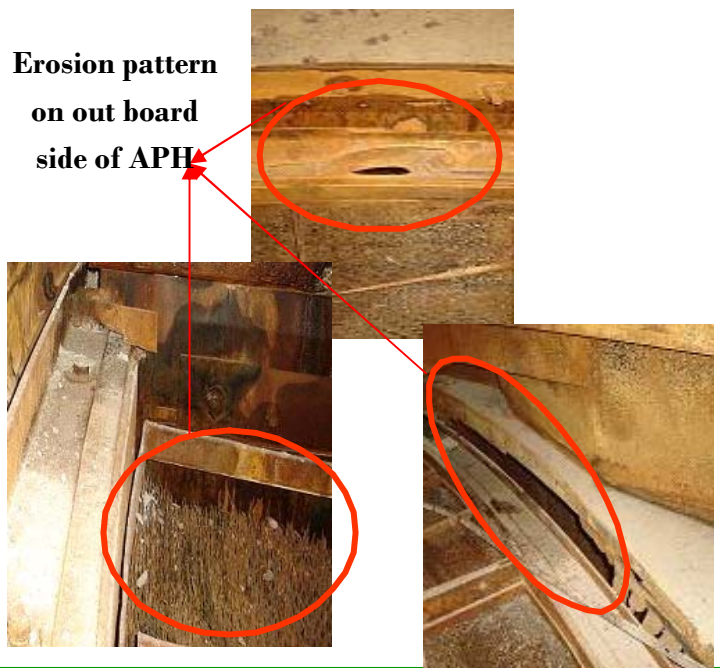



PERFORMANCE IMPROVEMENT IN REGENERATIVE AIR PREHEATERS

CHOKING OF HEATING ELEMENTS

In addition to improper soot blowing and water washing during outage, non uniform distribution of gas is also the reason for choking of elements. Uniform

distribution of flue gases shall minimize this problem. Moreover heat transfer to air through elements shall improve.

MECH-WELL'S ROLE IN DISTRIBUTION OF FLUE GAS & APH PERFORMANCE IMPROVEMENT

Mechwell Industries is involved in maintenance, services & performance improvements of rotary air pre-heaters for power plants.

Computational Fluid Dynamic (CFD) is used for fluid-flow simulation and heat-transfer simulation in 3D model of a rotary regenerative heat exchanger. The three-dimensional distributions of the flue-gas velocity, the temperature and the percentage of O₂ in the flue-gas over the entire computational model is possible through CFD technique.

The experimental result and CFD simulation result can be compared for increasing the performance of air pre-heater.

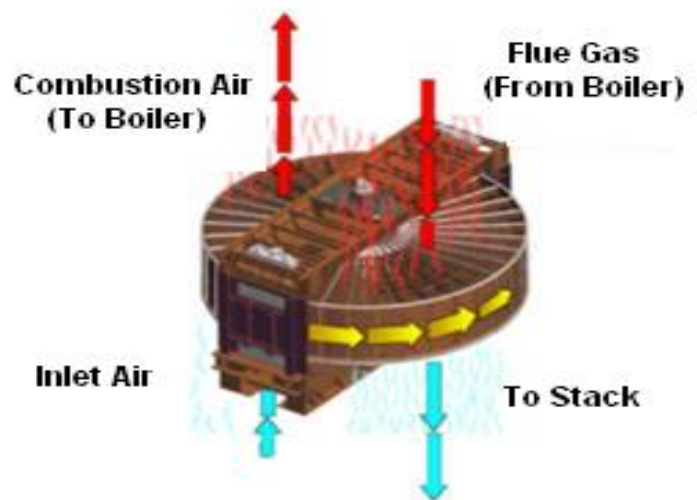
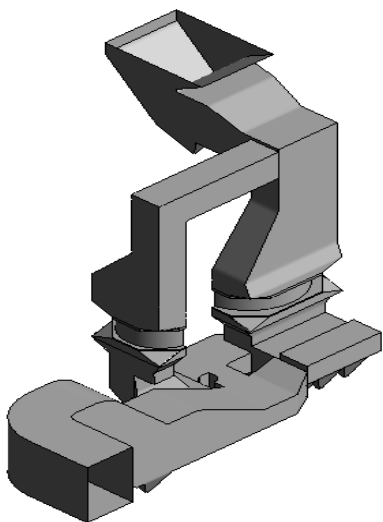

During each revolution of the rotor, heat is absorbed by the heating surface passing through the hot gas stream and transferred to the combustion air stream. CFD is an effective tool to simulate various configurations of the heating element arrangement, profiles, materials and plate-thickness to achieve **maximum heat transfer, minimum pressure drop and good clean ability.**

CFD analysis can help to predict flow distribution in the air/flue gas path of air pre-heater. Optimization of the air/flue gas stream can be possible by modification in the flow path by means of reducing the turbulent flow in the duct which results in reduction of pressure drop.

PERFORMANCE IMPROVEMENT IN REGENERATIVE AIR PREHEATERS

MECH-WELL'S ROLE IN DISTRIBUTION OF FLUE GAS & APH PERFORMANCE IMPROVEMENT

MWI has carried out R&D & CFD analysis to improve the performance of the Air Preheater.

AIR HEATER FLUE GAS FLOW ANALYSIS FOR 210 MW THERMAL POWER PLANT

In the thermal power plant of 210 MW the mass flow of the flue gas stream is not uniformly distributed over the air pre-heater. Major flow is going towards the outer wall of the duct; it causes erosion at the outer duct and also erosion along the outboard portion of the rotor. Due to the erosion and non uniform distribution of flue gas, the heat transfer to the heating element is not proper. MWI have carried out CFD analysis of flow pattern to air pre-heater. Suitable design modifications are carried in the duct to make the flow uniform.

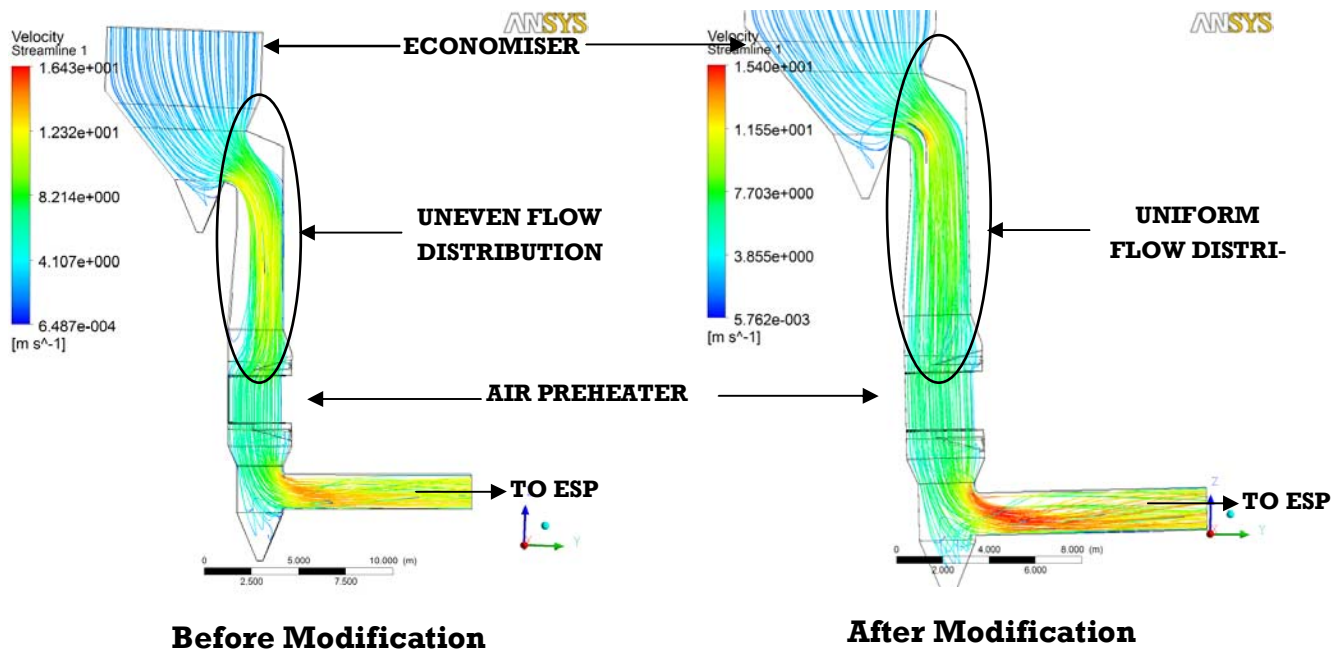

Flow Profile From Economiser Outlet to Air Heater Outlet (210 MW)

PERFORMANCE IMPROVEMENT IN REGENERATIVE AIR PREHEATERS

MECH-WELL'S ROLE IN DISTRIBUTION OF FLUE GAS & APH PERFORMANCE IMPROVEMENT

AIR HEATER FLUE GAS FLOW ANALYSIS FOR 500 MW THERMAL POWER PLANT

500MW boilers supplied by BHEL are provided with four bisector APHs, two for primary and two for secondary air. Flue gas from economizer outlet duct is distributed in four branches. Two are going to SAPH and remaining to PAPH. The ducts going to SAPH are located just beneath the economizer outlet. The ducts going to PAPH take longer path and that too with two

90 degree bends due to layout requirement. Flue gas flow is not apportioned properly for heating primary and secondary air. Mass flow unbalance causes uneven extraction of heat by APH. Flue gas temperature leaving P.A.P.H. and S.A.P.H. differ by about 50 to 60 degrees centigrade, resulting in increased loading on I.D. fans and erosion of ducts and dampers.

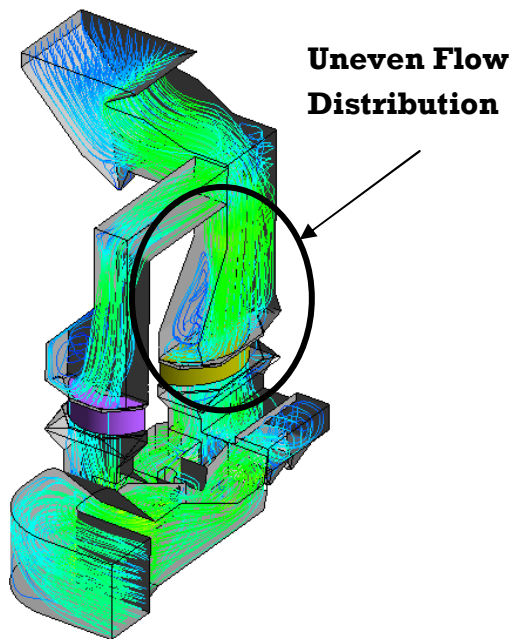

**Uneven Flow
Distribution**

Before Modification

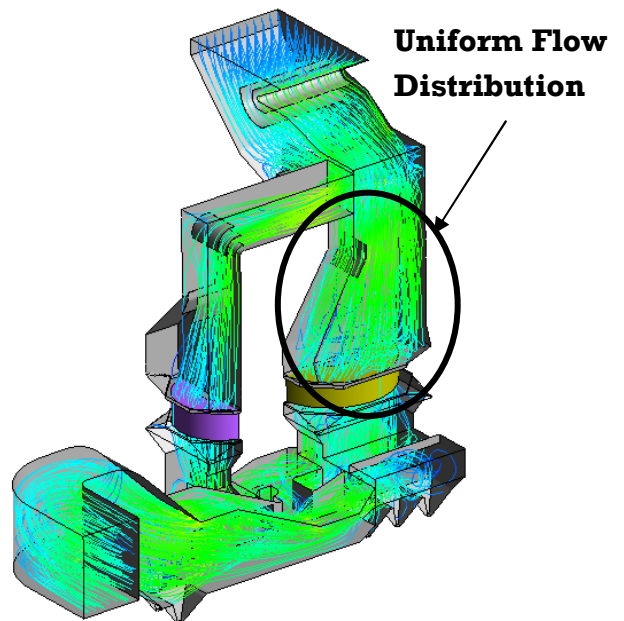

**Uniform Flow
Distribution**

After Modification

Flow Profile From Economiser Outlet to Air Heater Outlet (500 MW)

Flue gas distribution to PAPH and SAPH as per requirement is carried out by CFD Analysis & subsequent modifications in the APH inlet ducts.

Numerical model is being developed to assess the leakages from different seals i.e. Hot end radial, cold end radial, and bypass seals.

MECHWELL INDUSTRIES LTD.

7-A, Old Anjirwadi,
Ground Floor, P.O. Box 6208,
Mazgaon,
Mumbai - 400 010.

Phone: 022-66200300
Fax: 022-66200380
E-mail: mechwell@vsnl.com

Let's Grow Green



WE ARE ON THE NET
www.mechwell.com

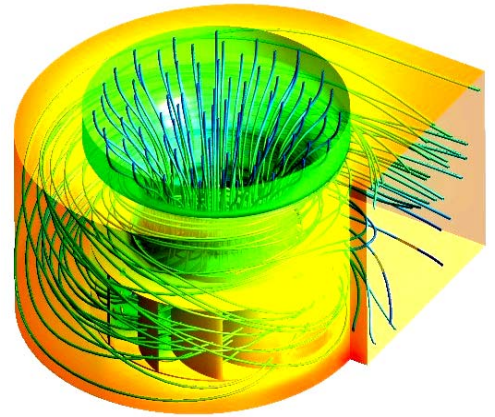

CFD CONSULTANCY

Mechwell has the facilities for Computational Fluid Dynamics (CFD) Analysis & the same can be carried out for:-

1. Second pass of boiler.
2. Air Preheater.
3. Ducts.
4. ESP
5. Fans.
6. Silencers (Acoustics Solutions)

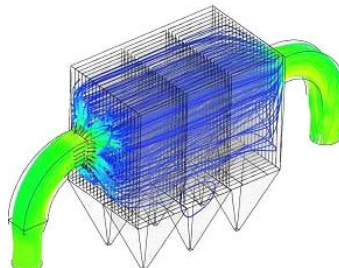
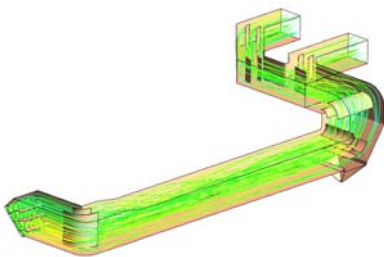
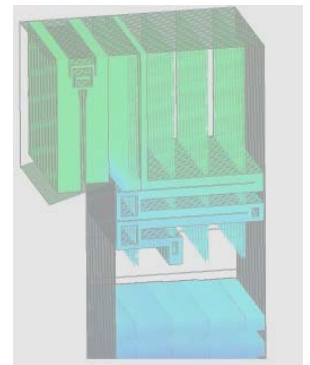

Our vision is to conduct an integral program of research, consulting & professional development to promote & demonstrate globally the role of design & innovation in achieving environmentally sustainable future.

